



# 3-Pin Microprocessor Power Supply Supervisors



## FEATURES

- Precision monitoring of +3.3V (-5%, -10%), 5V (-10% Power Supplies)
- Active low reset output
- Reset valid down to  $V_{CC} = 1.0V$
- 6 $\mu A$  power supply current
- Power supply transient immunity
- Industrial temperature range: -40°C to +85°C
- RoHS-compliant SOT-23 package

## APPLICATIONS

- Computers
- Servers
- Laptops
- Cable modems
- Wireless communications
- Embedded control systems
- White goods
- Power meters
- Intelligent instruments
- PDAs and handheld equipment

## DESCRIPTION

The CAT853, CAT863, CAT859, and CAT869 are supervisory circuits that monitor power supplies in digital systems.

These devices generate a reset signal, which is asserted while the power supply voltage is below a preset threshold level and for at least 140ms after the power supply level has risen above that level. Industry standard threshold levels are offered to support +3.3V or 5.0V systems.

The CAT859 and CAT869 feature a  $\overline{RESET}$  push-pull output (active low) for the two pinout options.

The CAT853 and CAT863 feature an open drain  $\overline{RESET}$  output (active low). Both require a pull-up resistor on the  $\overline{RESET}$  output.

Fast transients on the power supply are ignored and the output is guaranteed to be in the correct state at  $V_{CC}$  levels as low as 1.0V.

For Ordering Information details, see page 9.

## PIN CONFIGURATION

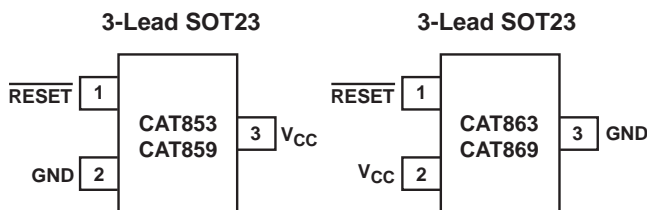

## THRESHOLD SUFFIX SELECTOR

Nominal Threshold Voltage	Threshold Suffix Designation
4.38V	M
3.08V	T
2.93V	S
2.4V	C

## PIN DESCRIPTIONS

Name	Description
$\overline{RESET}$	Active low reset. $\overline{RESET}$ is asserted if $V_{CC}$ falls below the reset threshold and remains low for at least 140ms after $V_{CC}$ rises above the reset threshold.
GND	Ground
$V_{CC}$	Power supply voltage that is monitored.

# CAT853, CAT863, CAT859, CAT869

## BLOC DIAGRAMS

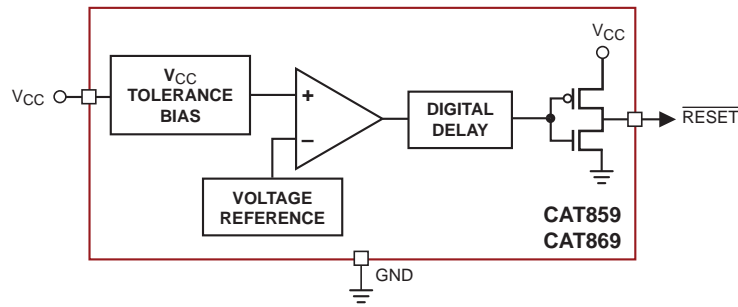
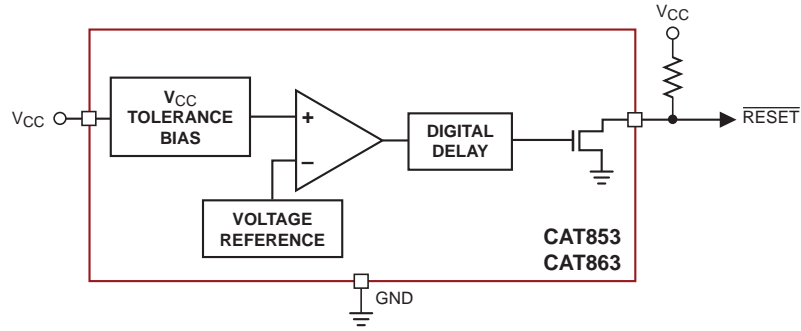

**ABSOLUTE MAXIMUM RATINGS<sup>(1)</sup>**

Any pin with respect to ground	-0.3V to +6.0V
Input Current, $V_{CC}$	20mA
Output Current, $\overline{\text{RESET}}$	20mA
Rate of Rise, $V_{CC}$	100V/ $\mu$ s
Continuous Power Dissipation Derate 4mW/ $^{\circ}$ C above 70 $^{\circ}$ C (SOT23)	320 mW
Operating Temperature Range	-40 $^{\circ}$ C to +85 $^{\circ}$ C
Storage Temperature Range	-65 $^{\circ}$ C to +105 $^{\circ}$ C
Lead Soldering Temperature (10 sec)	300 $^{\circ}$ C

**Note:**

(1) Stresses above those listed under "Absolute Maximum Ratings" may cause permanent damage to the device. These are stress ratings only, and functional operation of the device at these or any other conditions outside of those listed in the operational sections of this specification is not implied. Exposure to any absolute maximum rating for extended periods may affect device performance and reliability.

**ELECTRICAL CHARACTERISTICS**

$V_{CC}$  = Full range,  $T_A$  = -40 $^{\circ}$ C to +85 $^{\circ}$ C unless otherwise noted. Typical values at  $T_A$  = +25 $^{\circ}$ C and  $V_{CC}$  = 3.3V for the C, S, T versions,  $V_{CC}$  = 5V for the M version.

Parameter	Symbol	Conditions	Min	Typ <sup>(1)</sup>	Max	Units	
$V_{CC}$ Range		$T_A$ = 0 $^{\circ}$ C to +70 $^{\circ}$ C	1.0		5.5	V	
		$T_A$ = -40 $^{\circ}$ C to +85 $^{\circ}$ C	1.2		5.5		
Supply Current	$I_{CC}$	$T_A$ = -40 $^{\circ}$ C to +85 $^{\circ}$ C $V_{CC}$ < 3.6V, C, S, T		6	15	$\mu$ A	
Reset Threshold Voltage	$V_{TH}$	M Threshold	$T_A$ = +25 $^{\circ}$ C	4.31	4.38	4.45	V
			$T_A$ = -40 $^{\circ}$ C to +85 $^{\circ}$ C	4.25		4.50	
		T Threshold	$T_A$ = +25 $^{\circ}$ C	3.04	3.08	3.11	
			$T_A$ = -40 $^{\circ}$ C to +85 $^{\circ}$ C	3.00		3.15	
		S Threshold	$T_A$ = +25 $^{\circ}$ C	2.89	2.93	2.96	
			$T_A$ = -40 $^{\circ}$ C to +85 $^{\circ}$ C	2.85		3.00	
		C Threshold	$T_A$ = +25 $^{\circ}$ C	2.35	2.40	2.45	
			$T_A$ = -40 $^{\circ}$ C to +85 $^{\circ}$ C	2.30		2.50	
Reset Threshold Tempco				30		ppm/ $^{\circ}$ C	
$V_{CC}$ to Reset Delay		$V_{CC}$ = $V_{TH}$ to ( $V_{TH}$ - 100 mV)		20		$\mu$ s	
Reset Active Timeout Period		$T_A$ = -40 $^{\circ}$ C to +85 $^{\circ}$ C	140	240	460	ms	
$\overline{\text{RESET}}$ Output Voltage Low	$V_{OL}$	$V_{CC}$ = $V_{TH}$ min, $I_{SINK}$ = 1.2mA			0.4	V	
		$V_{CC}$ > 1.0V, $I_{SINK}$ = 50 $\mu$ A			0.3		
$\overline{\text{RESET}}$ Output Voltage High	$V_{OH}$	$V_{CC}$ = $V_{TH}$ max, $I_{SOURCE}$ = -500 $\mu$ A (for CAT859/869 only)	0.8 $V_{CC}$			V	

**Note:**

(1) Production testing done at  $T_A$  = +25 $^{\circ}$ C; limits over temperature guaranteed by design only.

# CAT853, CAT863, CAT859, CAT869

## TYPICAL OPERATING CHARACTERISTICS

$V_{CC}$  = Full range,  $T_A$  =  $-40^{\circ}\text{C}$  to  $+85^{\circ}\text{C}$  unless otherwise noted. Typical values at  $T_A$  =  $+25^{\circ}\text{C}$ ,  $V_{CC}$  = 3.3V for C, S, T versions, and  $V_{CC}$  = 5V for the M version.

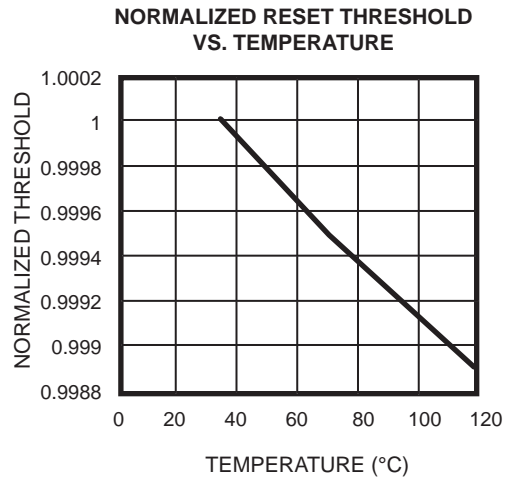
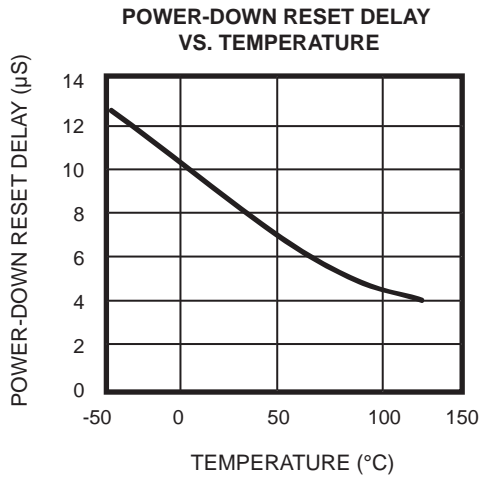
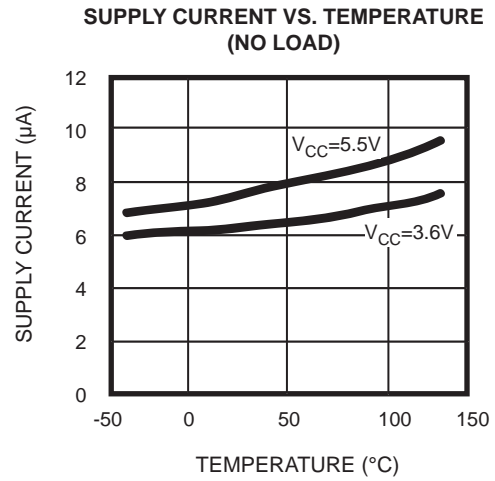
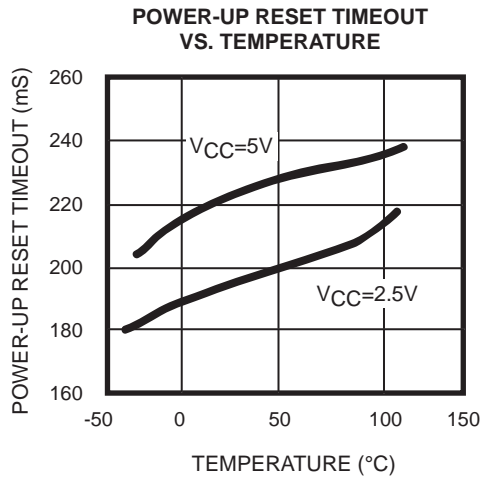

## DETAILED DESCRIPTIONS

### RESET TIMING

The reset signal is asserted low for the CAT853, CAT863, CAT859, and CAT869 when the power supply voltage falls below the threshold trip voltage and remains asserted for at least 140ms after the power supply voltage has risen above the threshold.

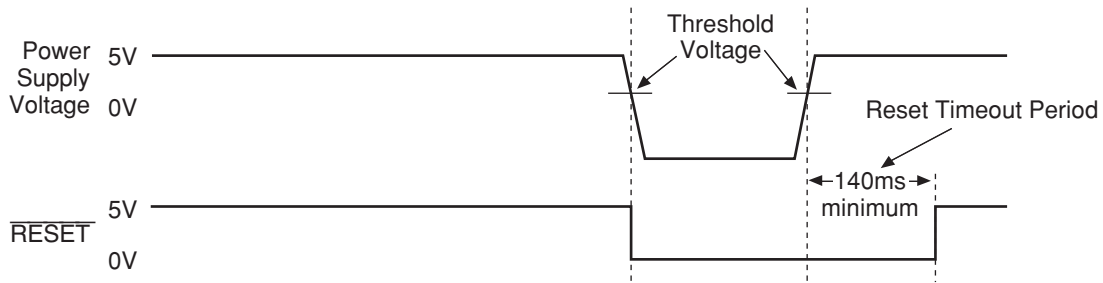

Figure 1. Reset Timing Diagram

### V<sub>CC</sub> TRANSIENT RESPONSE

The CAT853, CAT863, CAT859, and CAT869 protect  $\mu$ Ps against brownout failure. Short duration transients of 4 $\mu$ sec or less and 100mV amplitude typically do not cause a false RESET.

Figure 2 shows the maximum pulse duration of negative-going V<sub>CC</sub> transients that do not cause a reset condition.

As the amplitude of the transient goes further below the threshold (increasing  $V_{TH} - V_{CC}$ ), the maximum pulse duration decreases. In this test, the V<sub>CC</sub> starts from an initial voltage of 0.5V above the threshold and drops below it by the amplitude of the overdrive voltage ( $V_{TH} - V_{CC}$ ).

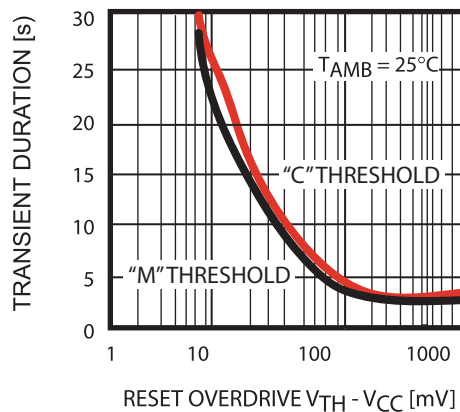

Figure 2. Maximum Transient Duration Without Causing a Reset Pulse vs. Reset Comparator Overdrive

## VALID RESET WITH $V_{CC}$ UNDER 1.0V

To ensure that the CAT859 and CAT869  $\overline{\text{RESET}}$  pin is in a known state when  $V_{CC}$  is under 1.0V, a  $> 10\text{k}\Omega$  pull-down resistor between  $\overline{\text{RESET}}$  pin and GND is recommended.

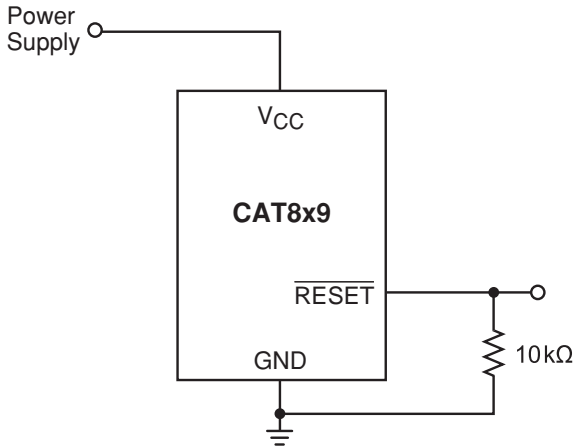

Figure 3.  $\overline{\text{RESET}}$  Valid with  $V_{CC}$  Under 1.0V

## BI-DIRECTIONAL RESET PIN INTERFACING

The CAT859 and CAT869 can interface with  $\mu\text{P}/\mu\text{C}$  bi-directional reset pins by connecting a  $4.7\text{k}\Omega$  resistor in series with the CAT859 and CAT869 reset output and the  $\mu\text{P}/\mu\text{C}$  bi-directional reset pin.

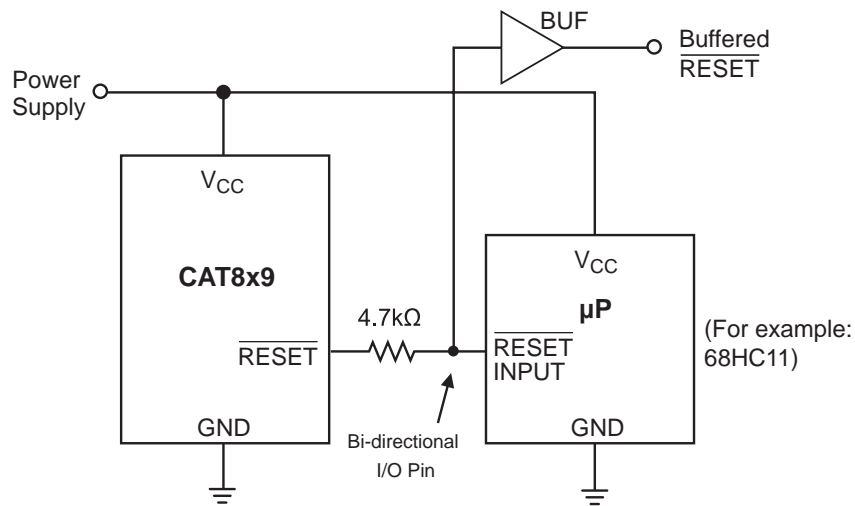

Figure 4. Bi-directional Reset Pin Interfacing

**CAT853 AND CAT863 OPEN-DRAIN  $\overline{\text{RESET}}$  APPLICATION**

The CAT853 and CAT863 features an open-drain RESET output and therefore need a pull-up resistor on the output for proper operation, as shown on Figure 5. An advantage of the open-drain output includes the ability to “wire AND” several outputs together to form an inexpensive logic circuit. It is also possible to have the pull-up resistor connected to a different supply which can be higher than the CAT8x3  $V_{CC}$  pin. The value of the pull-up resistor is not critical in most applications, typical values being between  $5k\Omega$  and  $10k\Omega$ .

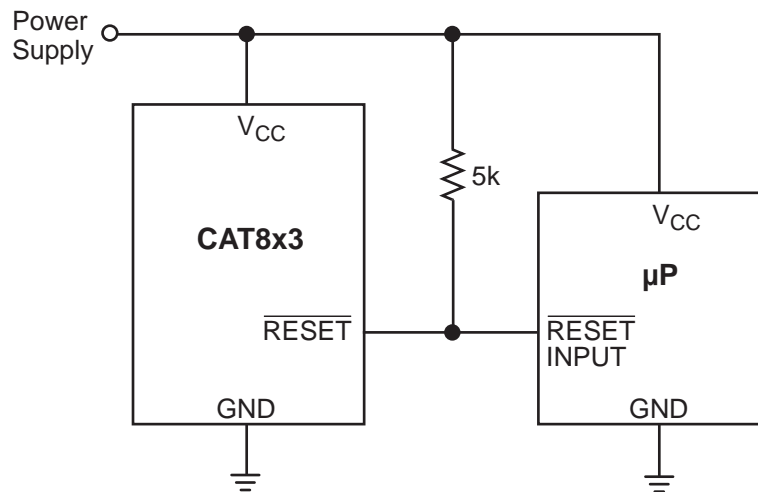
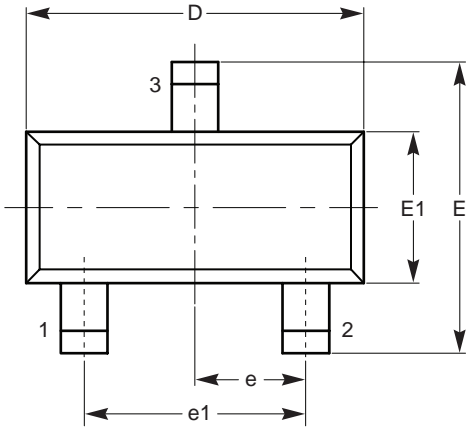

Figure 5. Typical CAT8x3 Open-Drain Circuit Configuration

PACKAGE OUTLINE DRAWING

SOT-23 3-Lead (TB)



TOP VIEW

SYMBOL	MIN	NOM	MAX
A	0.89		1.12
A1	0.013		0.10
b	0.37		0.50
c	0.085		0.18
D	2.80		3.04
E	2.10		2.64
E1	1.20		1.40
e	0.95 BSC		
e1	1.90 BSC		
L	0.400 REF		
L1	0.540 REF		
	0°		8°

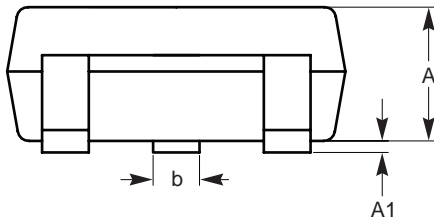

SIDE VIEW

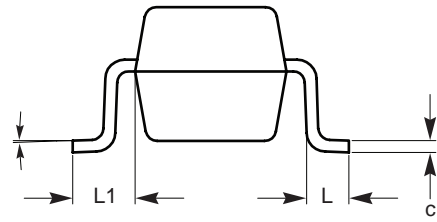

END VIEW

For current Tape and Reel information, download the PDF file from:  
[www.catsemi.com/documents/tapeandreeel.pdf](http://www.catsemi.com/documents/tapeandreeel.pdf)

Notes:

- (1) All dimensions are in millimeters. Angles in degrees.
- (2) Complies with JEDEC standard TO-236.



**EXAMPLE OF ORDERING INFORMATION (1) (2) (3)**

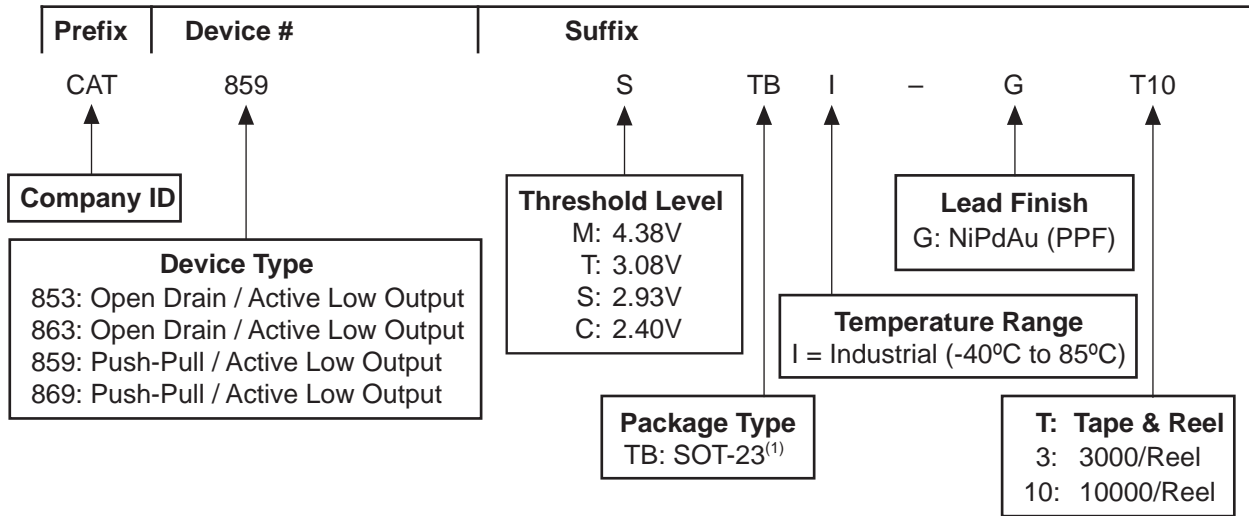

**TOP MARKING**

Part and Threshold	SOT-23 RoHS NiPdAu Finish <sup>(4) (5)</sup>	Part and Threshold	SOT-23 RoHS NiPdAu Finish <sup>(4) (5)</sup>
CAT859C	RSYM	CAT853C	RUYM
CAT859T		CAT853T	
CAT859S		CAT853S	
CAT859M		CAT853M	
CAT869T	RTYM	CAT863T	RVYM
CAT869S		CAT863S	
CAT869M		CAT863M	

**ORDERING PART NUMBER (6)**

CAT859CTBI-G	CAT869TTBI-G	CAT853CTBI-G	CAT863TTBI-G
CAT859TTBI-G	CAT869STBI-G	CAT853TTBI-G	CAT863STBI-G
CAT859STBI-G	CAT869MTBI-G	CAT853STBI-G	CAT863MTBI-G
CAT859MTBI-G		CAT853MTBI-G	

**Notes:**

- (1) All packages are RoHS-compliant (Lead-free, Halogen-free).
- (2) The device used in the example above is a CAT859STBI-GT10 (Push-Pull / Active Low Output, trip level of 2.85V to 3.00V NiPdAu, Tape and Reel).
- (3) For additional package and temperature options, please contact your nearest ON Semiconductor Sales office.
- (4) The "YM" in the SOT-23 package marking indicates the Year and Month of production.
- (5) All NiPdAu devices will be marked to indicate product type. Threshold and full part numbers will be provided on box and reel labels as well as all Shipping documents.
- (6) For special threshold and package options, contact factory.

**REVISION HISTORY**

Date	Rev.	Description
11-Oct-06	A	Initial Issue CAT859, CAT869
4-May-07	B	Added CAT853, CAT863 Update Example of Ordering Information Update Top Marking Update Ordering Part Number
17-Jan-07	C	Add Threshold Level - C: 2.40V Update Package Outline Drawing Add MD- to document number
30-Jan-08	D	Added Block Diagrams
5-Nov-08	E	Change logo and fine print to ON Semiconductor

ON Semiconductor and  are registered trademarks of Semiconductor Components Industries, LLC (SCILLC). SCILLC reserves the right to make changes without further notice to any products herein. SCILLC makes no warranty, representation or guarantee regarding the suitability of its products for any particular purpose, nor does SCILLC assume any liability arising out of the application or use of any product or circuit, and specifically disclaims any and all liability, including without limitation special, consequential or incidental damages. "Typical" parameters which may be provided in SCILLC data sheets and/or specifications can and do vary in different applications and actual performance may vary over time. All operating parameters, including "Typicals" must be validated for each customer application by customer's technical experts. SCILLC does not convey any license under its patent rights nor the rights of others. SCILLC products are not designed, intended, or authorized for use as components in systems intended for surgical implant into the body, or other applications intended to support or sustain life, or for any other application in which the failure of the SCILLC product could create a situation where personal injury or death may occur. Should Buyer purchase or use SCILLC products for any such unintended or unauthorized application, Buyer shall indemnify and hold SCILLC and its officers, employees, subsidiaries, affiliates, and distributors harmless against all claims, costs, damages, and expenses, and reasonable attorney fees arising out of, directly or indirectly, any claim of personal injury or death associated with such unintended or unauthorized use, even if such claim alleges that SCILLC was negligent regarding the design or manufacture of the part. SCILLC is an Equal Opportunity/Affirmative Action Employer. This literature is subject to all applicable copyright laws and is not for resale in any manner.

**PUBLICATION ORDERING INFORMATION**

**LITERATURE FULFILLMENT:**

**Literature Distribution Center for ON Semiconductor**  
P.O. Box 5163, Denver, Colorado 80217 USA  
**Phone:** 303-675-2175 or 800-344-3860 Toll Free USA/Canada  
**Fax:** 303-675-2176 or 800-344-3867 Toll Free USA/Canada  
**Email:** orderlit@onsemi.com

**N. American Technical Support:** 800-282-9855 Toll Free  
USA/Canada  
**Europe, Middle East and Africa Technical Support:**  
Phone: 421 33 790 2910  
**Japan Customer Focus Center:**  
Phone: 81-3-5773-3850

**ON Semiconductor Website:** [www.onsemi.com](http://www.onsemi.com)  
**Order Literature:** <http://www.onsemi.com/orderlit>  
For additional information, please contact your local  
Sales Representative